

## SMA-40, SMA-60, SMA-120 40, 60, AND 120 WATT MIXER-AMPLIFIERS

### INTRODUCTION

These instructions contain the specifications and information necessary to install, operate, and maintain the SMA-40, 40 Watt Mixer-Amplifier, the SMA-60, 60 Watt Mixer-Amplifier and the SMA-120, 120 Watt Mixer-Amplifier manufactured by Clarity, 1111 Industry Avenue., Roanoke, VA 24013.

**"WARNING: To reduce the risk of fire or electric shock, do not expose this appliance to rain or moisture."**

**"WARNING: Shock Hazard - Do Not Open."**

**"AVIS: Risque de Choc Electrique ne pas Ouvrir."**

### SPECIFICATIONS

#### Purpose

The SMA-40 Mixer-Amplifier provides up to 40 watts of audio power, the SMA-60 provides 60 watts, and the SMA-120 provides up to 120 watts of audio power for voice paging or background music systems.

#### Applications

- Clarity Paging and Sound Reinforcement Systems
- Clarity Stand Alone Background Music Systems

Refer to Figure 1 for a block diagram of a typical installation.

#### Features

- Active mix or Priority override on inputs (override is voice operated)
- Shelf or rack mount (optional kit)
- Mic 1/Tel on Input 1, 3 standard MIC/AUX inputs
- Volume control for each input
- Master volume control
- Bass control
- Treble control
- Circuit breaker protection
- ON/OFF switch
- Overload limiting circuit protection



- Screw terminals for all connections
- Power "ON" indicator
- 2 ohm, 25 and 70 volt outputs on the SMA-120
- 4 ohm, 25 to 70 volt outputs on the SMA-40 and SMA-60
- Knobs for all controls
- Clipping indicator
- Effects loop
- Tape output
- Booster output

#### Dimensions and Weight

- 17.1"W x 12.5"D x 3.9"H  
(43.43cm W x 31.75cm D x 9.9cm H)
- 24 lbs. (10.8 Kg) - SMA-120
- 20 lbs. (9.1 Kg.) – SMA-40 and SMA-60

#### Power Requirements

Voltage	120 VAC
Current (SMA-40)	1.0 Amps
(SMA-60)	1.6 Amps
(SMA-120)	3.0 Amps

#### Environment

Temperature	0 to 50 Degrees C
Humidity	0 to 85% non-precipitating

**947408**

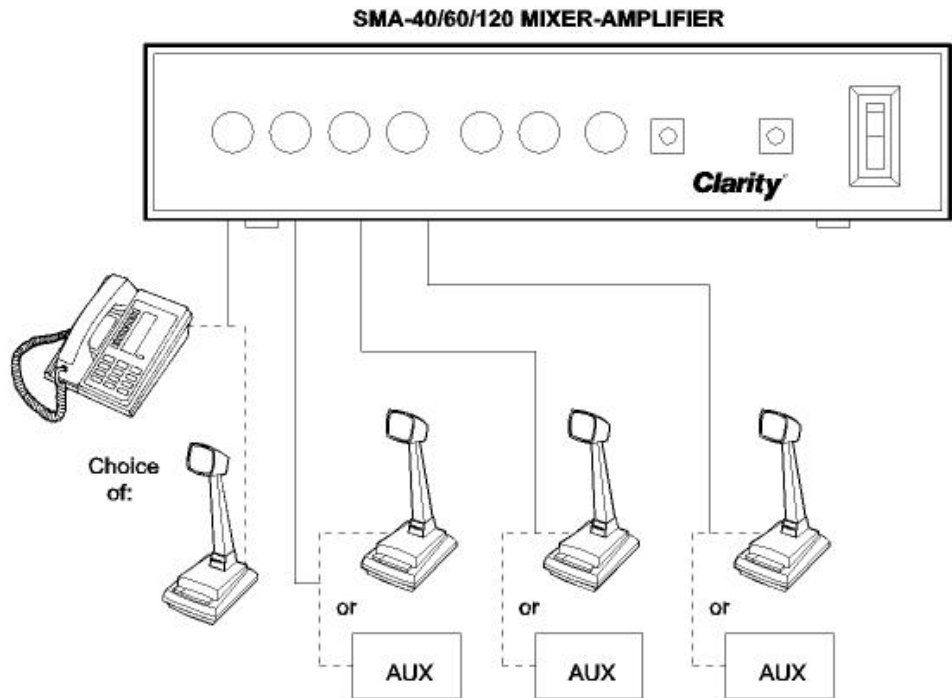

**FIGURE 1 - TYPICAL INSTALLATION BLOCK DIAGRAM**

**Nominal Specifications**

Wattage Output (SMA-40)	40 Watts RMS
Type Outputs (SMA-40)	4 ohm or 25V or 70V
Wattage Output (SMA-60)	60 Watts RMS
Type Outputs (SMA-60)	4 ohm or 25V or 70V
Wattage Output (SMA-120)	120 Watts RMS
Type Outputs (SMA-120)	2 ohm or 25V or 70V

For All Models:

Frequency Response	30-20KHz $\pm$ 2dB
Distortion	< 2% @ 1KHz Rated Output
Number of Inputs	4 (1 Mic/Tel Line, 3 Mic/Aux)
Mounting	Wall or Rack
Voice Switch Sensitivity	-31dbm
Mic Input Impedance	600 ohm Balanced
Sensitivity on Mic Input	1.0mV RMS
Tel Line Input Impedance	600 ohms
Tel Line Sensitivity	200mV RMS
Aux Impedance	10K ohms
Aux Sensitivity	200mV RMS
Effects Out	1V RMS $\pm$ 20%
Effects In	1V RMS 10K
Tape Out	1V RMS 10K
Booster Out	2.6V 10 K Loading
Loading Level	10K High

**DESIGN**

The SMA-40 and SMA-60 amplifiers can be used to operate 4 ohm, 25 or 70.7 volt type speakers and horns and the SMA-120 amplifier can be used to operate 2

ohm, 25 or 70.7 volt type speakers and horns. These mixer-amplifiers will actively mix all inputs or will provide priority inputs. If priority input is selected, the Mic/Tel input will override all inputs that are active. (Refer to Table 1 in the Operation Section for the override sequence). When the amplifier is in the priority mode, the switching is voice operated. (No contacts are required).

These amplifiers have a master volume control plus a separate volume control for each input. Bass and treble controls are also provided.

A circuit breaker is provided on the back of these units and will operate in the event of a catastrophic overload. The mixer-amplifier contains a limiting circuit for protection against short circuits or impedance mismatches. The units will shut down in the event of a trouble condition and reactivate automatically when the condition is corrected.

The amplifiers can be either shelf or rack mounted (rack mount kit is optional).

**INSTALLATION**

**General**

Figure 2 shows volume control locations. Figure 3 shows output terminal strips and switches on the back of the amplifier as well as typical connections to the mixer-amplifier.

NOTE: If the effects loop is not used, the slide switch should be in the **OFF** position.

### **Mounting**

The SMA-40, 60 and 120 were designed for shelf or rack mounting. Make certain the unit is not mounted near heat sources or strong magnetic fields. Verify control and terminal strip accessibility. The unit may be rack mounted. Order the associated rack mount kit SMA-RMK.

### **MIC Connections**

These units provide connections for low impedance balanced microphones. Connect the positive pressure lead of the microphone (normally pin 2 of a standard XLR connector) to MIC (+) terminal connection, microphone shield to MIC COM terminal and the negative pressure lead of the microphone to the remaining MIC terminal connection as shown in Figure 3.

### **Telephone System 600 Ohm Page Port Connection**

When using these mixer-amplifiers with a 600 ohm telephone system page port, connect page port Tip to the TEL (+) terminal and connect page port Ring to TEL-COM as shown in Figure 4.

**NOTE:** *Interface devices are required when connecting to outside C.O. Lines, PABX extensions, or single line telephones.*

### **Auxiliary Connections**

High impedance auxiliary devices such as a tuner, tone generator, etc. can be connected to the AUX input. Phono jacks are provided at the rear of the amplifier for each of the auxiliary inputs.

### **Speaker Cabling**

When the 2 or 4 ohm output is used, standard two conductor speaker wire can be used (18-20 AWG determined by the load). If the 25 or 70V output is used, two conductor shielded cable is recommended for speaker connections. NOTE: When shielded cable is used, the shield should be connected to the Ground terminal located on the back of the amplifier.

### **Priority Override**

To enable the cascading priority override feature, install a wire strap on the two terminals marked priority on the back of the amplifier (see Figure 3).

### **Amplifier Setup**

During initial system set up, it is recommended that the individual gain controls be set 1/4 turn clockwise and the master volume control be set 1/2 turn clockwise.

**All connections should be made to the amplifier and double-checked before the AC power cord is plugged in.** The power indicator will illuminate when the AC power cord is plugged in and the power switch is in the "ON" position.

## **OPERATION**

These units provide two modes of operation, either active mix or priority override.

When the amplifier is in the active mix mode signals on all inputs are mixed and sent to the speakers. When the priority input is selected, a signal on the MIC/TEL input will override all other active inputs (See Table 1 for override sequence). The override is voice activated and does not require the use of an external relay or contact closure. The separate gain controls on the unit allow adjustment of the volume levels of each input.

A clipping light is provided on the front of the unit. This light will illuminate when the output signal exceeds the power rating of the amplifier.

Input	Priority Level
Mic 1/TEL	1
Mic 2/Aux 1	2
Mic 3/Aux 2	3
Mic 4 /Aux 3	4

NOTE: Level 1 is highest priority.

## **TECHNICAL ASSISTANCE**

When trouble is reported, verify that AC power is being supplied to the unit and there are no shorts or grounds on cabling.

Assistance in troubleshooting is available from the factory. When calling, you should have a VOM available and be calling from the job site. Call (540) 427-3505 and ask for Technical Support or (540) 427-6000 for Clarity 24-hour Automated Support.

Clarity equipment is not field repairable. Clarity maintains service facilities in Roanoke, VA. Should repairs be necessary, attach a tag to the unit clearly stating company name, address, phone number, contact person, and the nature of the problem. Send the unit to:

**Clarity**  
**Repair and Return Dept.**  
**5614 Hollins Road**  
**Roanoke, VA 24019-5056**

## TROUBLESHOOTING CHART

<b>PROBLEM</b>	<b>POSSIBLE SOLUTION</b>
No Output.	<ol style="list-style-type: none"> <li>1. Verify AC power is being supplied to the unit and the power switch is in the "ON" position.</li> <li>2. Verify that input signal is present at amplifier connection.</li> <li>3. If speaker controller or equalizer is not being used, make sure that effects switch is in the "OFF" position.</li> <li>4. Verify all speaker wiring (no opens, shorts, or grounds).</li> </ol>
Distorted output.	<ol style="list-style-type: none"> <li>1. Check input wiring for proper polarity connections.</li> <li>2. Verify that speaker load does not exceed amplifier rating.</li> <li>3. Verify input signal does not exceed input voltage rating.</li> <li>4. Verify all speaker wiring (no opens, shorts, or grounds).</li> </ol>
Override does not operate.	<ol style="list-style-type: none"> <li>1. Verify priority strap is installed.</li> <li>2. Verify input signal is at proper level.</li> </ol>

### **LIMITED WARRANTY**

**Clarity** warrants its products to be free from defects in materials and workmanship under conditions of normal use and service for a period of one year from the date of shipment. The obligation under this warranty shall be limited to the replacement, repair or refund of any such defective device within the warranty period, provided that:

1. Inspection by Clarity indicates the validity of the claim;
2. The defect is not the result of damage, misuse, or negligence after the original shipment;
3. The product has not been in any way repaired by others and that factory sealed units are unopened (A service charge plus parts and labor will be applied to units defaced or physically damaged);
4. Freight charges for the return of products to Clarity are prepaid,
5. All units "out of warranty" are subject to a service charge. The service charge will cover minor repairs (Major repairs will be subject to additional charges for parts and labor).

**This warranty is in lieu of and excludes all other warranties, expressed or implied, and in no event shall Clarity be liable for any anticipated profits, consequential damages, loss of time or other losses incurred by the buyer in connection with the purchase, operation, or use of the product.**

This warranty specifically excludes damage incurred in shipment. In the event a product is received in damaged condition, the carrier should be notified immediately. Claims for such damage should be filed with the carrier involved in accordance with the F.O.B. point.

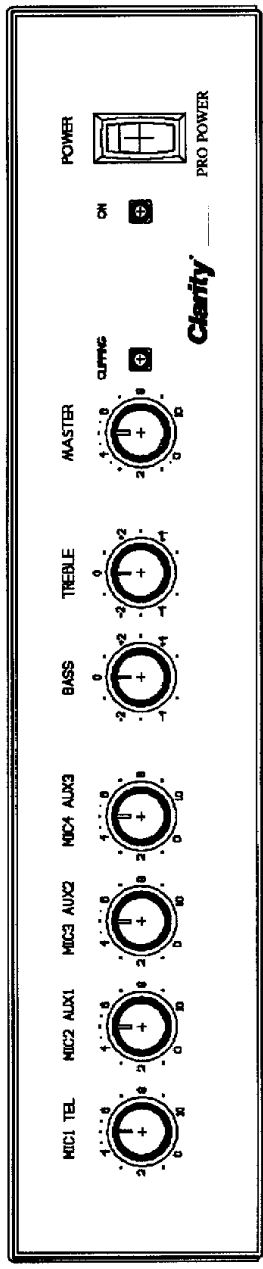

FIGURE 2 - SMA-40/60/120 Mixer-Amplifier (Front View)

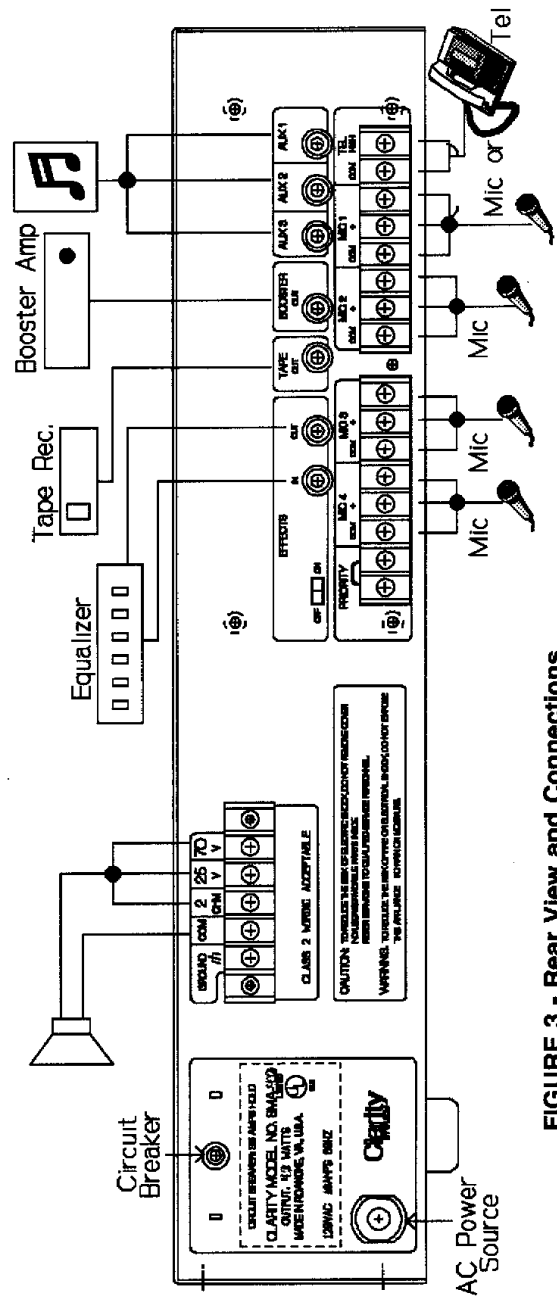

FIGURE 3 - Rear View and Connections